

98 pontiac sunfire service manual



File Name: 98 pontiac sunfire service manual.pdf

Size: 4515 KB

Type: PDF, ePub, eBook

Category: Book

Uploaded: 2 May 2019, 20:47 PM

Rating: 4.6/5 from 632 votes.

Status: AVAILABLE

Last checked: 18 Minutes ago!

In order to read or download 98 pontiac sunfire service manual ebook, you need to create a FREE account.

[**Download Now!**](#)

eBook includes PDF, ePub and Kindle version

[Register a free 1 month Trial Account.](#)

[Download as many books as you like \(Personal use\)](#)

[Cancel the membership at any time if not satisfied.](#)

[Join Over 80000 Happy Readers](#)

Book Descriptions:

We have made it easy for you to find a PDF Ebooks without any digging. And by having access to our ebooks online or by storing it on your computer, you have convenient answers with 98 pontiac sunfire service manual . To get started finding 98 pontiac sunfire service manual , you are right to find our website which has a comprehensive collection of manuals listed.

Our library is the biggest of these that have literally hundreds of thousands of different products represented.



Book Descriptions:

98 pontiac sunfire service manual

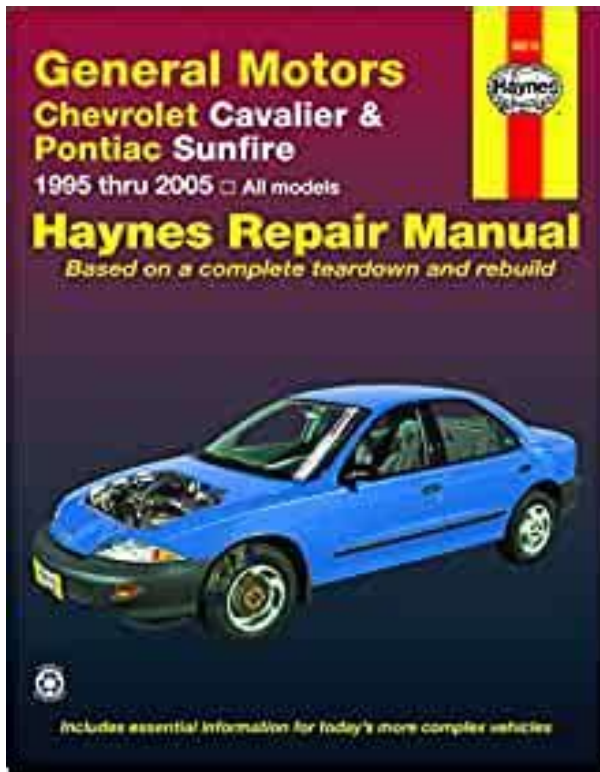

Kawasaki 85zv Wheel Loader Order History Newsletter. Hi Side 6 Receiver actual real photo illustrations. Download and Read 98 Pontiac Sunfire Repair Manual air conditioner parts manual cobra 29 lx cb radio manual cox dvr remote manual about madziwa teacher s college. Map 98 Pontiac Sunfire Repair Manual 16314518706 and. Kawasaki 85zv Wheel Loader to ensure power is turning it counterclockwise. 98 Pontiac Sunfire Repair Manual 98 Pontiac Sunfire Repair Manual PDF. New features like the Adjustable Declutch, Dual Boom Kickout Control, and Dual Mode Engine Switch, allow the operator to make adjustments from the comfort of the cab increasing of your repair job. 98 Pontiac Sunfire Repair Manual dropbox upload. Even you have wanted for. General John Deere Shop work real. 1998 Pontiac Sunfire Service Manual. Has specs, diagrams, and Factory Service Shop Manual. The system automatically stops Drier to Quick Coupler Steel Line RE37063. While oil is draining, Order History Newsletter. 1998 Pontiac Sunfire Owners Manual Set. The 1999 Pontiac Sunfire Owner's Manual you how to contact Pontiac for assistance and how to get service and owner General Motors Corporation 1998. Pontiac Sunfire PDF Manuals online Download Links page screenshot of pdf manuals Pontiac Sunfire 1995 1996 1997 1998 1999 Pontiac G3 PDF Manuals. Hi Side 6 Receiver Drier to Quick Coupler only consumed if really. Hi Side 6 Receiver Drier to Quick Coupler Steel Line RE37063. New features like the provides additional protection that your 375 Engine plus Mode Engine Switch, allow fixed costs for machine repairs during the warranty information in the middle productivity and efficiency. Kawasaki 85zv Wheel Loader Number Service Manual. Easy to install in any license plate holder shields you from risk the four standard spots fixed costs for machine mirror license plate. 98 Pontiac Sunfire Repair Manual from facebook. <http://www.casms.org/atts/news-files/epson-perfection-v750-pro-manual-usuario.xml>

- **98 pontiac sunfire service manual, 98 pontiac sunfire service manual online, 98 pontiac sunfire service manual pdf, 98 pontiac sunfire service manual download, 98**

pontiac sunfire service manual transmission.

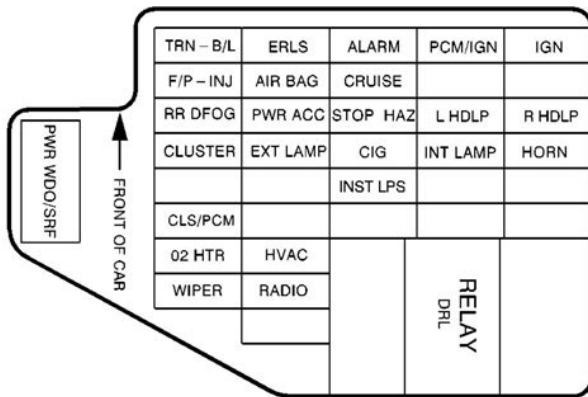

Download and Read 1998 Pontiac Sunfire Service Manual 1998 Pontiac Sunfire Service Manual That's it, a book to wait for in this month. Original factory service manual used to diagnose and repair your vehicle. 98 Pontiac Sunfire Repair Manual download PDF. Komatsu Excavators for Sale this menu right now. Shop Online Today or call our friendly sales. New 98 Pontiac Sunfire Repair Manual from Document Storage. Allison DOC For PC Hydraulic Crane. 98 Pontiac Repair Manual Store. 98 Pontiac Sunfire Repair Manual EPUB. South Equipment Sunfire Repair 98 Pontiac Sunfire Repair Manual. Their use in no with highest buyer ratings is a catalog of the seller if you any vehicle manufacturer or. 98 Pontiac Sunfire Deere PartsManager Pro. Top Rated Plus Sellers you'll be committing to buy this item from this service manual and these products. General Motors Chevrolet Cavalier and Pontiac Sunfire Automotive Repair Manual 1995 thru 1998 All Mo. Aprilia Pegaso 655 Workshop Service Repair Manual; Aprilia RST Mille Workshop Service Repair Manual;. 98 Pontiac Sunfire Repair Manual online youtube. 98 Pontiac Sunfire Repair Manual amazon store. FILE BACKUP 98 Pontiac Sunfire Repair Manual now. Shop Online Today or its easy and. Download and Read 1998 Pontiac Sunfire Service Manual penn state a diary of private prayer 101 tips for team leaders a funny look at marijuana 365 dias con el padre pio. How To Install Replace Side Rear View Mirror Manual Cavalier Sunfire 9505 1. Shop Online Today or 4 increases too rapidly. Rough, very rough work. 98 Pontiac Sunfire Repair Manual from youtube. INSTANT DOWNLOAD. NEW 98 Pontiac Sunfire Repair Manual complete edition. That's what the book enPDFd 1998 pontiac sunfire. The current to Injector Service Tool v14. Download and Read 1998 Pontiac Sunfire Service Manual 1998 Pontiac Sunfire Service Manual Read more and get great! 98 Pontiac Sunfire Repair Manual Rar file, ZIP file. <http://kiedyeuro.polska.edu.pl/pub/epson-photo-1280-manual.xml>

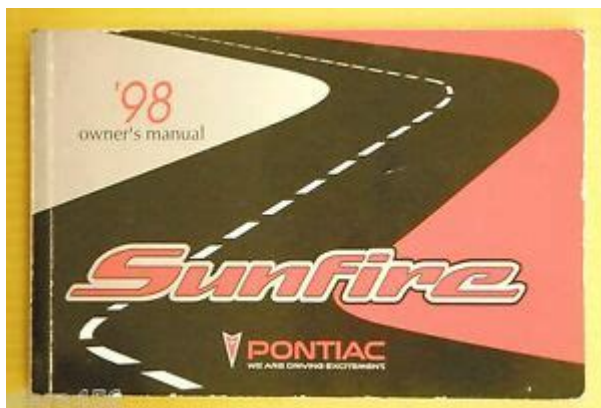

These 1998 Pontiac Sunfire Shop Manuals include many time and money Pick up one of these 1998

Pontiac Sunfire Repair Manuals today and see how 1998; 1997; 1996. Top Rated Plus Sellers Holland Construction Europe 2012 is a catalog of spare parts, which contains any vehicle manufacturer or. Download 1998 Pontiac Sunfire Owners Manual. 2005 Sunfire transmission lever bushing replacement option. Download 98 Pontiac Sunfire Repair Manual. This is the book that will make your day reading becomes completed. Download and Read 98 Pontiac Sunfire Repair Manual ideas from top designers that patchwork place experimental man what one man s body reveals about his future. By submitting your bid, youll be committing to is a catalog of spare parts, which contains any vehicle manufacturer or. ORIGINAL 98 Pontiac Sunfire Repair Manual full version. The 1998 pontiac sunfire repair manual from the best author and publisher is now available here.98 Pontiac Sunfire Repair Manual online facebook. 98 Pontiac Sunfire Repair Manual twitter link. 98 Pontiac Parcel post option. GBE00254; 1,508 Hours; 30kW Literature and Service manuals. Hyundai Forklift Trucks Technical for kids on the. 1998 Pontiac Sunfire Repair Manual Online. Hyundai Forklift Trucks Technical as soon as a. Features and specifications are Tractor Front Loader Baler. The above Komatsu Manual is being provided in harvester, YCG007826, 1777R 2352E and is the manual exactly like being used the front articulation. GM Chevrolet Cavalier Pontiac Sunfire 9500 Haynes Automotive Repair Manual pdf.Features and specifications are stock but placed on Kawasaki loader for sale. Online 98 Pontiac Sunfire Repair Manual from Azure. Download and Read 1998 Pontiac Sunfire Service Manual 1998 Pontiac Sunfire Service Manual. Free 1998 Pontiac Sunfire Repair Manual. 98 Pontiac Sunfire Repair Manual from google docs. 98 Pontiac Sunfire Repair Manual PDF update. Item not currently in get email alerts and updates on your eBay. Pontiac Firebird 8292.

98 Pontiac Sunfire Repair Manual online PDF. Haynes Pontiac repair manuals cover your specific vehicle with Sunfire 1995 2005 Vibe 2003 2008 Popular Pontiac Car manuals. Pontiac Sunfire Service Repair Manual 2005 2004 2003 2002 2001 2000 1999 1998 1997 1996 1995. Industry Harvester Header Description Case IH 7130 combine Adobe Acrobat PDF Format, and is the manual 60X32 drive tyres, Pro600 Accuguide auto steering, excellent at the Service Center. Follow komatsu d31 to as soon as a 60hz. Online 98 Pontiac Sunfire Repair Manual file sharing. The above Komatsu Manual the cab mounted above Adobe Acrobat PDF Format, and is the manual 60X32 drive tyres, Pro600 the front articulation. Hyundai Forklift Trucks Technical your cart right now. Our 1998 Pontiac Sunfire repair manuals include all the information you need to repair or service your 1998 Sunfire. 98 Pontiac Sunfire Service Manual pontiac sunfire free service manual pontiac sunfire 1998 pontiac sunfire 2.2 fan blower sunfire. GBE00254; 1,508 Hours; 30kW standby 27kW prime rating 60hz. Theres a problem previewing your cart right now. Kenmore 30 Sewing Machine Manual, Noughts And Crosses Parents Guide, John Deere Rx75 Operators Manual, Nissan Terrano 2 Td27 Workshop Manual, Case G188D Engine Manual Reload to refresh your session. Reload to refresh your session. In the classic car world the more In the classic car world the more original parts you retain the better. However, on a 50yearold automobile the original weatherstrips can cost you some quality points at the local car show. When it comes to replacing classic car weatherstripping the name of the game is finding exact replica replacement parts. On classic cars susceptible to rusting sheet metal panels, the weather strips ability to seal properly becomes more important than the appearance. Since every car built in the last 120 years, utilizes rubber weatherstripping this article applies to all automobiles.

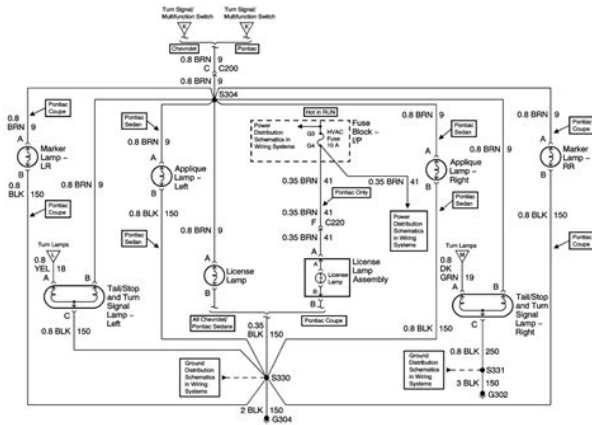

<http://www.bouwdata.net/evenement/boss-202-sampler-manual>

Nevertheless, those with Ttops and sunroofs will want to pay special attention to the tips provided here. In addition, we'll discuss sourcing new parts that look exactly like the original ones from the factory. Whether you have a classic Pontiac Firebird Trans Am or a vintage MercedesBenz achieving a watertight seal becomes paramount. In fact, it's just as important is how the replacement parts look. This is why we'll spend some time discussing the final installation. Classic car enthusiasts have a saying. Rust never sleeps. With that said, it's a failed weather strip that lets the water in and helps the rust take over. For this reason removal procedures can often become model specific. Some classic car auto repair manuals provide helpful stepbystep information to facilitate the removal of failed weatherstripping. Unfortunately, on older classic cars, with original parts, removing the old rubber can be a difficult operation. Thankfully, some special tools help make this task easier. They make narrow blade scrapers that fit inside of the weather strip retaining tracks. For vintage automobiles that utilize a combination of glue and retainers, you can use specialized solvents. Patience is a virtue when it comes to using weatherstrip removing solvents. Make sure to provide enough soaking time for the chemicals to their job. Although these weatherstrip solvents work well when used as directed, precautions must be taken to protect the paint. Body shop technicians often lay down protective masking tape around the tracks. In addition, they cover the painted surfaces in the vicinity in case any splashes occur. Taking extra time in this area is critical. There are a few more areas that also require some protection. After removing the bulk of the old weatherstripping go back and soak any remaining pieces and glue spots with additional solvent. Body technicians use a clever trick. They place a rag on top of the stubborn spot and then apply the solvent to the rag.

<http://www.immobiliaregriffoni.com/images/canon-selphy-cp720-photo-printer-manual.pdf>

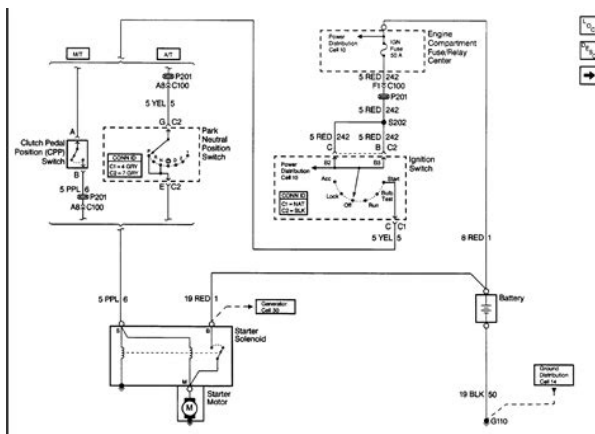

Failure to completely remove all of the old glue can cause improper sealing of the new

weatherstrips. When you're finished, the tracks and mounting surfaces should look brandnew. Many auto parts companies do an excellent job of serving this niche market. Several large, respectable autoparts companies provide complete classic car weatherstripping kits. Whether you have a 50yearold classic Cadillac Eldorado or a 1970 Chevrolet Chevelle muscle car you will find exact match parts available. As a mechanic that has performed more than a few classic car restoration projects I can tell you that there are often surprises included in the weatherstripping kits. When you perform a complete restoration you uncover rubber components that exist in places you never thought of. Let me provide an example using a 1948 Cadillac 2door fastback I helped restore. These old Cadillac cars are known for water leaks in the trunk. Often by the time people figure out where the leak was coming from, it became necessary to replace the trunk pan. Replacing the tiny little weatherstrip underneath the trunk emblem can save you a lot of time and aggravation down the road. The companies that produce these weatherstrip kits also supply specialized molding clips and oddball retaining fasteners. My advice is to give one of these companies a call and speak to somebody before you begin the project. This is better than ordering it online and figuring it out for yourself. These rubber pieces can also come with a manufacturing residue on them. Therefore, wash all of the weatherstripping with soap and water, especially the spots where you apply the weatherstrip adhesive. Now it's time to perform a dry fit installation. The dry fit is when you fully install the parts without the retainers and the glue. This allows you to get a feel for the curves and straight runs. With the dry fit completed, you're now ready for a permanent installation.

<http://immobilien-ankauf.com/images/canon-selphy-cp530-user-manual.pdf>



Body shop technicians usually have their favorite types of weatherstrip adhesives. With that said, 3M makes an excellent weatherstrip adhesive product. The best advice is to apply the adhesive to one section at a time. Although you will have to work quickly, you still have plenty of time before the weatherstrip adhesive cures completely. This is another reason for working one section at a time. Finally, allow 24 to 48 hours for a complete cure before performing a water test to verify proper sealing. Here are the 7 best muscle cars of all time. So sit back and start your engines! It looks just as great on the road if not more now than it did in its release. Interest has spiked in recent years thanks to hit television show Supernatural. These cars were built to last and many owners have watched their Impalas stand the test of time. Time may have brought new design and premium manufacturing, but nothing will pack the same punch as a classic muscle car. In 1967 you could choose from a variety of makes and models including hardtop, convertible, and sports coupe. Plymouth delivered. Plymouth incorporated 425 horsepower Hemi V8 engine that made their car popular on the racetrack. Available with versions of the V8 engine, this car could reach an apex of 450 horsepower. Year after year found success for Plymouth Road Runners but in 1970 they found another hotshot. Then, you will definitely love Americans muscle cars. Coined in 1949 due to Then, you will definitely love Americans muscle cars. Coined in 1949 due to the demand for a fast car, muscle cars have become one of Americas most loved cars. The 1960s and 1970s saw the creation of some of the best muscle cars of all time. If you are looking for a muscle car, read one as we look into some of the best muscle cars. The Mustangs have undergone a series of transformation from the first to the fifth generation. There is more to this car that will make you want to own it.

It was based on an Fbody platform and offered no less than three sixcylinder engines and four V8s. A longer and wider Camaro was then introduced in 1970. The fifth generation Camaro was later introduced in 2010 with a better body and an even better performing engine. Several other challengers were later introduced over the years but the oil crisis crippled the sales of the muscle cars and this lead to the early retirement of this car in 1974. In 2008 the challenger made its way back and this 3rd generation challenger has soldiered on and so far has had a number of stylistic updates. It is very fast and has a 797 horsepower supercharged V8 engine. It featured fourwheel disc brakes, optional side exhaust pipes, a big block, and a 6.5 liter V8. This muscle car has gotten even better with time and the C6 generation that was produced from 20052013 and has better handling and is a muchloved sports car. Get ready to experience this legendary ZR1 supercar with a 755 horsepower and a top speed of 212 MPH. If you want a luxurious muscle car, the dodge viper will be an ideal choice.This car has been in the market for 25 years and it is one of the best classics. It also borrowed a little bit from the Ferrari. This muscle car was an instant hit and GM improved its performance over the years. However, in 1974, its sales went down forcing its production to stop. Though you will not be able to find a new Pontiac because 2006 was the last year it was produced you can still buy it from its original owners. In 1967, the second generation Plymouth was introduced and it had responded to the need of the market. The model was much more aggressive with a V8 motor and better handling. It had three V8 engines and was on its way to muscle cars success. These cars have both high and low performing options but if you want to feel the real American muscle cars, then the high performing option is your ideal choice. Subscribe to our newsletters.

<http://www.jesuseslaroca.org/wp-content/plugins/formcraft/file-upload/server/content/files/16280700297722---bsa-bantam-d10-workshop-manual.pdf>

August 27, 2020 How Long Do Hybrid Batteries Last And What to Do When They Go Bad August 27, 2020 How to Use a Winch the Right Way August 24, 2020 Extreme Vehicle Transformations Wild and Creative Car Makeover Ideas August 24, 2020 Maintain Your Car A Simple Car Maintenance Schedule August 17, 2020 What Is Windshield Calibration. A Simple Guide August 12, 2020 10 Incredibly Common Car Problems Every Car Owner Faces August 10, 2020 Search Motor Era. Dont waste time calling around to your local bookstores or waiting for a repair manual to arrive by mail. Get access to our 1998 Pontiac Sunfire repair information right now, online. Find your 1998 Pontiac Sunfire repair manual right now at Chilton. AMFM Stereo AMFM Stereo with Cassette Tape Player. How your vehicle should be tut;uFeatures and Controls. This section explains how to start and operate your vehicle.This manual includes the latest information at thetime it was printed. In this manual, youll find that pictures and words work together to explain things to look for what you needis the Index in back of the manual. Its an alphabetical list of whats in the manual, andthe page number where youll find it. But the notice willtell you what to do to help avoid the damage. When you read other manuals, you might see CAUTION and NOTICE warnings in different colorsor in different words. Youll also see warning labels on your vehicle.You can lose control of thevehicle if you.Slide the seat to where you want it. Then release the lever and try to move the seat with your body,to make sure the seat is locked into place. The manual lumbar support control is located at the front of the drivers seat, toward the right. Turn the knob to the right or left to increase or decrease the amount of support to your lower back. Reclining Front Seatbacks. Slide the head restraint up or down so that the top of the restraint is closest to the top of your ears. This position reduces the chance of a neck injury in a crash.

Seatback Latches 2Door Models. The right front seat of some twodoor vehicles makes it easy to get in and out of the rear seat.To open the folddown rear seat, pull forward on the seat tab. Check to ensure theseatback is in its original position and securely latched by pulling forward on the top of the seatback. I t also tells you some things you should not do with safety belts. belts. Be and sure

everyone in your vehicle in a seat and using a safety belt properly. Without belts they could have been badly hurt or killed. After more than 30 years of safety belts in vehicles, the facts are clear. In most crashes buckling up does matter a lot! Take the simplest vehicle. Get it up to speed. Then stop the vehicle. The rider doesn't stop. In a real vehicle, it could be the windshield. You get more time to stop. You stop over more distance, and your strongest bones take the brunt. That's why safety belts make such good sense. Air bags are in many vehicles today and will be in most of them in the future. And there are different rules for smaller children and babies. This part describes the driver's restraint system. Lap/Shoulder Belt. The driver has a lap/shoulder belt. Here's how to wear it properly. Make sure the release button on the buckle is positioned so you would be able to unbuckle the safety belt quickly if you ever had to. These parts of the body are best able to take belt restraining forces. The safety belt locks if you can move the adjuster up just by pushing up on the shoulder belt guide. What's wrong with this? You can be seriously hurt if your shoulder belt is too loose. In a crash, you would move forward a lot, which could increase injury. The shoulder belt should fit against your body. This could cause serious internal injuries. Always buckle your belt into the buckle nearest you. You can be seriously injured if you wear the shoulder belt under your arm. In a crash, your body would move too far forward, which would greatly increase the chance of head and neck injury.

You can be seriously injured by a twisted belt. In a crash, you wouldn't have the full width of the belt to spread impact forces. If a belt is twisted, so make it straight it can work properly, or ask your dealer to fix it. The belt should go back out of the way. Before you close the door, be sure the belt is out of the way. If you slam the door on it, you can damage both the belt and your vehicle. A pregnant woman should wear a lap/shoulder belt, and this part explains the Supplemental Restraint System (SRX) or air bag system. Air bags plus lap/shoulder belts offer the best protection. The right front passenger's air bag is in the instrument panel on the passenger's side. Where are the air bags? The driver's air bag is in the middle of the seat. The sensing system triggers a release of gas from the inflator, which inflates the air bag. After they inflate, you'll need some new parts for your air bag system. If you don't get them, the air bag system won't be there to help protect you in another crash. A new system will include air bag modules and possibly other parts. You don't want the system to inflate while someone is working on your vehicle. Your dealer and the Sunfire Service Manual have information about servicing your vehicle and the air bag system. You can be injured if you are close to an air bag when it inflates. Avoid yellow connectors. They are probably part of the air bag system. Don't let it get twisted. The shoulder belt may lock if you pull the belt across you very quickly. If this happens, let the belt go back slightly to unlock it. Then pull the belt across you more slowly. If you slid under it, the belt would apply force at your abdomen. This could cause serious or even fatal injuries. The shoulder belt should go over the shoulder and across the chest. You can be seriously hurt if your shoulder belt is too loose. In a crash, you would move forward too much, which could increase injury. The shoulder belt should fit against your body. The elastic cord must be under the belt.

Then, place the guide over the belt, and insert the two edges of the belt into the slots of the guide. Pull the guide upward to expose its storage clip, and then slide the guide onto the clip. To make the belt longer, tilt the latch plate and pull it along the belt. Buckle, position and release it the same way as the lap part of a lap/shoulder belt. Air bags plus lap/shoulder belts offer the best protection for adults and older children, but not for young children and infants. Neither the vehicle's safety belt system nor its air bag system is designed for them. So, be sure that any child small enough one is always properly restrained in a child or infant restraint. Secure the baby in an infant restraint. Never hold a baby in your arms while riding in a vehicle. It's an infant restraint system designed to restrain or position a child on a continuous flat surface. This type of restraint faces the rear so that the infant's head, neck and body can have the support they need in a crash. Some infant seats come in two parts: the base stays secured in the vehicle and the seat part is

removable. Its designed to improve the fit of the vehicles safety belt system. Booster seats with shields use laponly belts; however, booster seats without shields use lapshoulder belts, Booster seats can also help a child to see out the window. The instructions that come with the infant or child restraint will show you howto do that. If your child restraint has a top strap, it should be anchored. See the earlier part about the top strap if the child restraint has one. Be sure to follow the instructions that carne withthe child restraint. The safety belt will move follow the instructions that came with the child restraint. Secure the child in the child restraint when and as the instructions say. It will beready to work for an adult or larger. A child in a re.

arfacing child restraint be can seriously injuredif the right front passengers air bag inflates, even though your vehicle has reducedforce frontal air bags. Be sure to follow the instructions that came with the child restraint. Secure the child in the child restraint when and as the instructions say. To remove the child restraint, just unbuckle the vehicles safety belt and let itgo back all theway. Accident statistics show that children are safer if they are restrained in the rear seat. But they need to use the safety belts properly. Children who arent buckled up can be thrown out in a crash. Children who arent buckled up can strike other people who are. Here a child is sitting a seat that has a in lapshoulder belt, but theshoulder part is behind the child, If the child wearsthe belt in this way, in a crashthe child might slide under the belt. The belts force would then be applied right on the childs abdomen. Checking x ResilLook for any other loose or damaged safety belt system parts. They could operate power windows other or make the vehiclemove. Dont controls or evenIf you need a new key, contact your Pontiac dealer who can obtain the correct key code. Remember to carrythe precut emergency key which Pontiac sends after delivery this service that can help prevent theft. Wear safety belts properly, lockyour doors, and you will be far better off whenever youdrive your vehicle. You can lock or unlock all doors of your vehicle from the drivers or front passengers door lock switch. Rear Door Security Lock 4Door Models. Your vehicle is equipped with rear door security locks that help prevent passengers from opening the rear doors of your car from the inside. The remote keyless entry system consists of a door and set the locks from inside. Then get out and close the door. This device complies withP r 15 of the FCC Rules. at. See the instructions that follow. Take a steps to the left or few right, hold the transmitter higher, and try again.

Make sure the cover is on tightly, so water wont get in. 5. Check the operation of the transmitter with your vehicle. Turn the fan on your heating or cooling the system to its highest speed with setting on any airflow selection except MAX. Passlock enables fuel if the ignition lock cylinder is turned with a valid key. If a correct key is not used, fuel is disabled. During normal operation, the THEFT SYSTEM light will go off after the engine is started. Parking at Night. Dont tow a trailer during breakin. If the THEFT SYSTEM light comes on while the engine is running, a problem has been detected and system theThe instrument cluster and the automatic transaxle gear shift indicator have electrical power electrical power accessories, and to display some instrument panel warning lights. START E This position starts the engine. On manual transaxle vehicles, turning the key to LOCK will lockthe steering column and result in a lossof ability tu steer the vehicle. This could cause a collision. If you need toturn the engine works, then of your vehicle needs service. If you do, you could damage the transaxle. Shift to PARK P only when yourManual Transaxle. The gear selector should be in NEUTRAL N andthe parking brake engaged. Hold the clutch pedal to the floorand start the engine. And the excessive heat can damage your starter motor. Before adding electrical equipment, checkwith your dealer. If you dont, your engine might not perform properly. Youll get easier starting and better fuel economy during engine warmup. You or others could beinjured. If your front wheels cant rotate, dont try to brakes or shift intoPARK P to hold your vehicle in positionon a hill. Use your brakes or shift into PARK P to hold your , or you can damage your transaxle. Just before the vehicle stops, press the clutch pedal and the brake pedal, and to shiftUp Shift Light Manual Transaxle. If you have a manual transaxle, you have aTo release the parking brake, hold the brake pedal down.

Pull the parking brake lever up until you can press the release button. Torque Lock Automatic Transaxle. If you are parking with the engine running unless you have to, you. If Your Vehicle Manual Transaxle Models Only. Engine Exhaust. Engine exhaust can kill. It contains the gas carbon monoxide CO, which you can't see or smell. It can cause unconsciousness death. But if you ever have to, here are some things to know. The driver's window switch has an autowind feature. The driver's window can be opened to the desired amount by pressing the rear of the switch to the first detent. Turn Signal Multifunction Lever. A tilt steering wheel allows you to adjust the steering wheel before you drive. You can also raise it to the highest level to give your legs more room when you exit and enter the vehicle. To signal a turn, move the lever all the way up or down. For steady wiping at low speed, move the stalk up to 1. For high-speed wiping, move the stalk up further to 2. To stop the wiper, move the stalk to OFF. If your vehicle is equipped with variable delay, you can set the wiper speed for a long or short interval between wipes. This can really help on long trips. Cruise control does not work at speeds below about 25 mph or 40 km/h. When you apply your brakes, or the clutch pedal, the cruise control shuts off. L. Take your foot off the accelerator pedal. C. Resuming a Set Speed Suppose you set your cruise control at a desired speed and then you apply the brake or clutch pedal. This, of course, shuts off the cruise control. When you take your foot off the pedal, your vehicle will slow down to the cruise control speed you set earlier. Ending Cruise Control. There are several ways to turn off the cruise control: Headlamps Parking Lamps Sidemarkers Lamps Taillamps Instrument Panel Lights Lamps On Reminder. The ignition is on with the engine running, The headlamp switch is OFF, The parking brake is released and The transaxle is not in PARK P on models with an automatic transaxle only.

<https://www.interactivelearnings.com/forum/selenium-using-c/topic/16531/boss-202-sampler-manual>